

**INSTALLATION INSTRUCTIONS
DEKORON / UNITHERM
ELECTRIC TRACED BUNDLES, HEATED HOSES,
HYBRID BUNDLES, AND
PROBE SUPPORT BUNDLES
FOR CEM APPLICATIONS**

Form INSTCEM040103

This bulletin provides the Field Engineer and the craft people with information for the proper installation of Dekoron / Unitherm Electrically Traced products. These recommendations have been proven by years of actual experience. They are put forth as suggestions and do not preclude the use of other methods and good field construction practices

This bulletin provides a general discussion on:

- Handling and Storage
- Planning and Preparation
- Product Installation

Topics such as:

- Methods of Installation
- Methods of Bending and Straightening
- Hanging and Support Instructions
- Electrical Connection Kits

are discussed in detail with the use of step-by-step instructions, illustrations, and diagrams. Various charts are included to cover product specifications, recommended support centers, and minimum bend radii, to guide in all phases of planning and installation.

HANDLING AND STORAGE

All Dekoron / Unitherm Traced products are shipped on non-returnable wooden reels, which take minimum space and provide maximum product protection. The standard reel for analyzer bundles has a 54" flange, is 36" wide, with a 40" drum, weighing 160 pounds. The standard reel for probe support bundles is 47"x16", with a 20" drum, weighing 40 pounds. Other reel sizes may be used, depending upon coil lengths.

Heated hose products may be shipped in non-returnable cardboard containers depending upon size and length. The standard size containers are 26"x26"x12" and 41"x41"x12". The smaller container can be shipped through most package services, the larger is shipped through a freight carrier.

Each length is sealed at the ends to prevent entry of moisture or foreign material. However, if reels are to be stored out of doors at the jobsite, a weatherproof covering (e.g., polyethylene film, canvas, etc.) should be used.

PLANNING AND PREPARATION

The methods recommended for installing Dekoron / Unitherm analyzer products are based upon accepted practices presently used by Instrument Engineers, Electricians and Pipe Fitters. Planning and preparation are essential to proper installation. Initial planning and system layout is recommended to take total advantage of the installation cost savings. **For fixed installations**, preliminary planning should encompass such things as: determination of run lengths, position and angle of sample and probe connections, accessible routing of the analyzer line, existing support structures and their location, entry into the analyzer house and analyzer cabinet, and the possibility of external tracing requirements beyond the bundle. It is important to review the section on hanging and supports while planning the run to make the best use of existing supports.

For portable applications, preliminary planning should encompass such things as: determination of run length, number of sections of analyzer line required, traffic patterns (to prevent damage to the heated line), accessible routing of the analyzer line, existing support structures and their location for temporary mouting, entry into the probe enclosure, total electrical power available (voltage and current), and insulation or heating required at bundle-to-bundle splices or at ends of the line.

Contact Dekoron / Unitherm Customer Service for information on the size, weight, support distance, and minimum bend radius of the bundle being installed.

LENGTH DETERMINATION

Bundle length is determined by the routing distance between sample point and instrument. However, some allowance for extra length should be made. Minimum additional length requirement for each connection point, such as splice, termination and input power kit, should be 12 inches. Allowances must also be made for routing inside probe enclosures and the analyzer housing.

For portable or heated hose applications, the length of the tubing and / or fittings at each end must also be determined. There must be sufficient free length of sample and support tubes or hoses to allow for connection to the probe, analyzer, or other hoses.

ROUTING FOR FIXED INSTALLATIONS

The initial consideration in establishing the best route is to install instruments and adjacent supports which will allow the traced line to run straight for 12" to 18" before being connected to any instruments, sample points, orifice plates, etc. This will simplify the job of connecting after the bundle is secured.

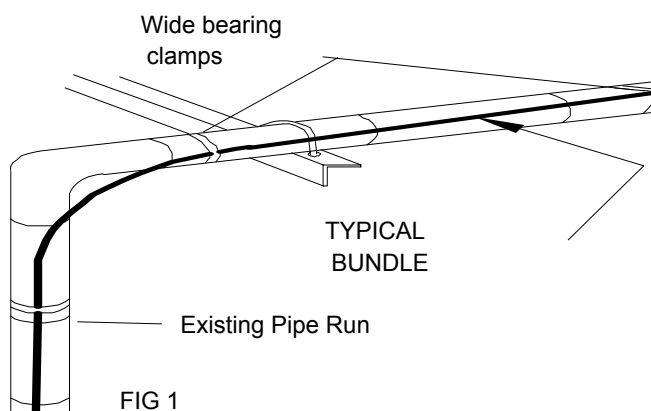

Routing should be chosen to take advantage of existing cable trays, beams, columns, etc. Provide long radius sweeping bends whenever possible. Long radius bends allow the bundle to work at its maximum efficiency and also provide a place where the bundle can expand and contract due to ambient and tube temperature changes. Tighter bends can be made, as explained below. Take care to insure that all bends are greater than the minimum bend radius. Support the bundle from 6 to 10 inches either side of the bend with wide bearing clamps (see fig. 1). The routing should not position the product in an area where the

ambient will reach above 120°F (49°C), such as near a boiler, reactor, heat exchanger, or against a hot chimney wall; unless the bundle is designed specifically to handle high ambient temperatures.

If the bundle is routed within an enclosed cable tray or conduit, this maximum temperature may be reduced.

Horizontal runs should be sloped to assist drainage of any condensate or particulate matter that may collect in the tube. Dekoron / Unitherm suggest a slope of 3/4 inch per foot of horizontal run. In systems where there is high gas velocity, this slope could be decreased.

Multiple bundle routing, where more than one bundle is run in parallel, should allow at least 1" space between bundles. Bundles may be stacked if insulating spacers, no less than 1" thick, are used.

ROUTING FOR TEMPORARY INSTALLATIONS

The initial consideration in establishing the best routing for analyzer bundles is placement of the analyzer equipment in relation to the monitoring point. The equipment should be close enough for reasonable analyzer line lengths, but positioned to allow for proper routing.

In addition to the items described in "Routing for Fixed Installations", above, the installer must consider routing through and over (or under) traffic areas. The heated bundle must be protected from damage due to vehicles and pedestrian traffic. It must also be protected from immersion in ditches or trenches. The illustration below shows some installation methods to use or avoid.

figure 2

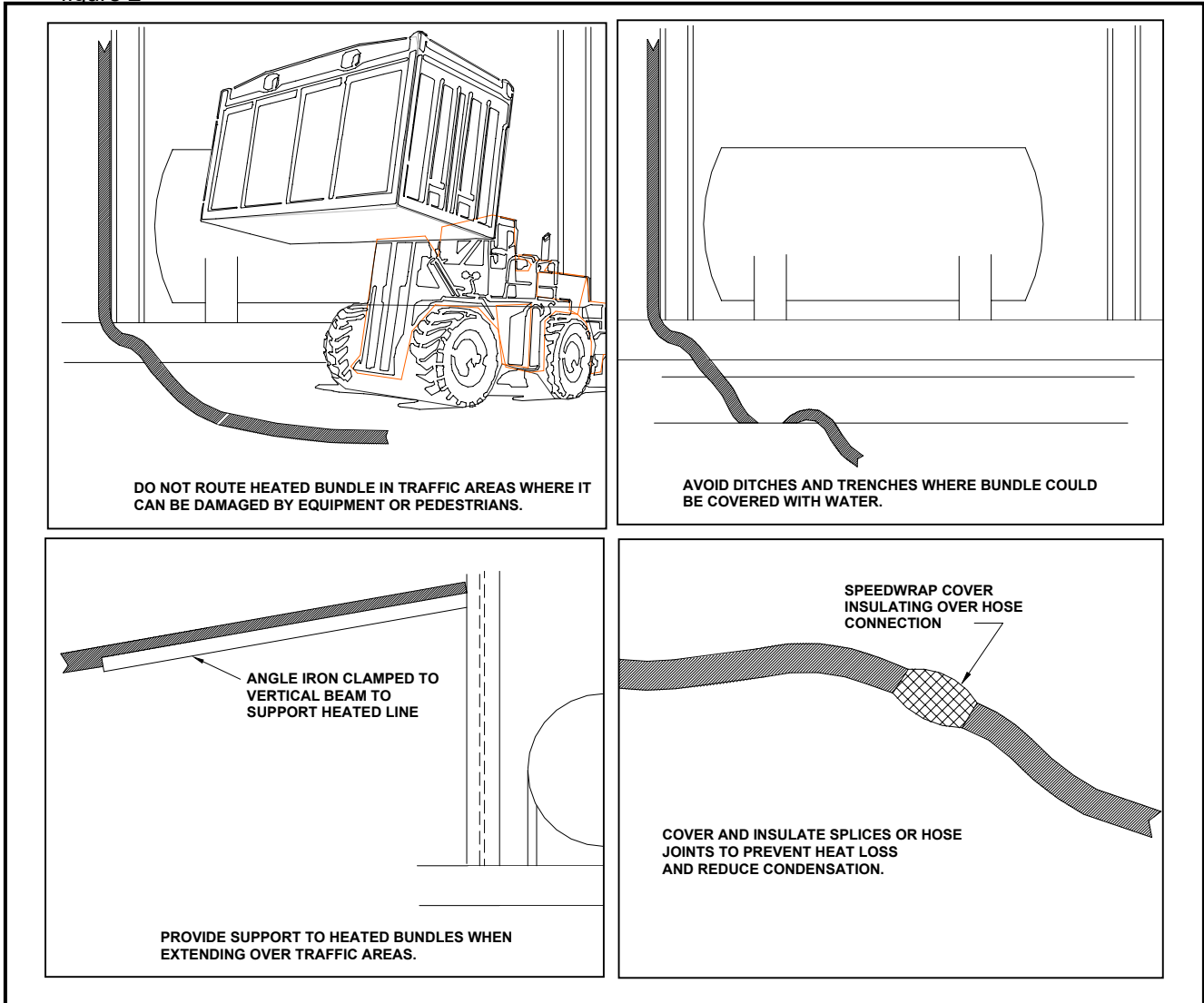

The Dekoron / Unitherm products range from semi-rigid Traced bundles to extremely flexible Heated Hoses. These products **cannot** be treated like power cables. The maximum pulling tension on most Dekoron / Unitherm analyzer bundles is less than 50 pounds, so they cannot be simply attached to a draw cable and pulled into place.

Installation generally begins at the probe end. If the probe is elevated, position the reel at the base of the stack, if possible directly below the line where the bundle will be secured. A draw cable can be fitted with split pulling grips (see Figs 2a and 3). These grips are attached to the bundle at intervals of 35 feet

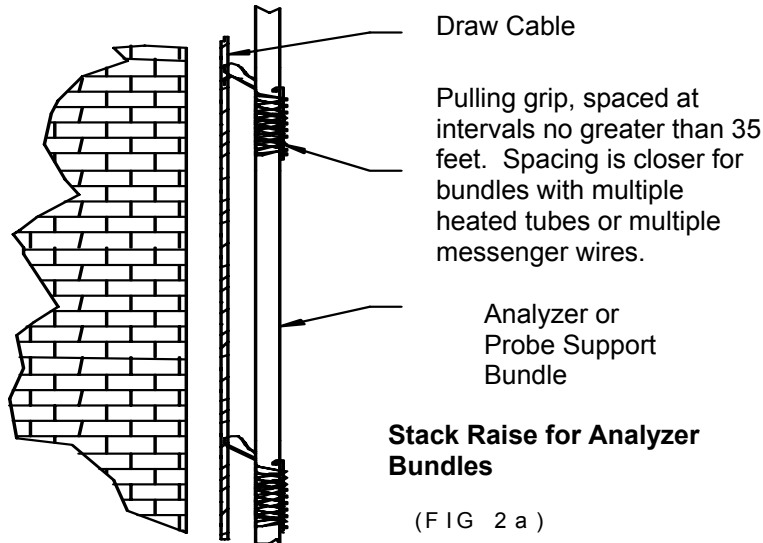

maximum. The cable and bundle are then pulled up to the level of the probe. **NOTE: the cable grip is not a recommended method for permanently securing the bundle to the stack. Other methods must be employed.** The cable grip can be used for temporary installations such as qualification testing or periodic certification tests. If the vertical run is offset around the stack from the probe location, the installer should pull sufficient bundle up the stack to

make the offset. The bundle is secured on the vertical run before routing the bundle around the stack. Do not attach pulling blocks at the top of the vertical run and pull the bundle from the probe location. The force applied at the pulling block is sufficient to damage the internal components even though there may be no apparent damage to the jacket.

Route the bundle from the vertical run to the probe. Again, allow extra bundle for routing into and connecting to the probe.

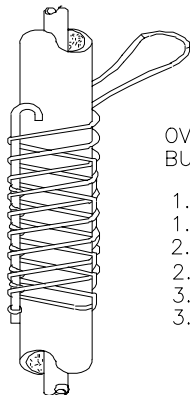

PULLING GRIP

| OVERALL BUNDLE OD | KELLEMS STANDARD SUPPORT GRIP |
|-------------------|-------------------------------|
| 1.50" TO 1.75" | P/N 022-03-007 |
| 1.75" TO 2.00" | P/N 022-03-008 |
| 2.00" TO 2.50" | P/N 022-03-009 |
| 2.50" TO 2.99" | P/N 022-03-010 |
| 3.00" TO 3.49" | P/N 022-03-011 |
| 3.50" TO 3.99" | P/N 022-03-012 |

(FIG 3)

- Plain Grips:** Kellems K100P or Reliable 824
- Split Grips:** Kellems UB125-A or Reliable 1863

Begin securing the bundle within 18 inches of the probe, using clamps and installation accessories detailed in the following sections. Never use wire or cable ties to secure Dekoron / Unitherm Analyzer bundles. Follow the bundle back from the probe, securing the bundle at the recommended support locations. Dekoron / Unitherm bundles are generally supported every 6 feet on a horizontal run and every 15

feet on a vertical run.

Once the bundle is secured at the base of the stack, it can then be routed along exiting structures or in cable trays to the analyzer house. At this point, the draw cable and cable grips can be removed and used on another bundle. Again, the bundle should be laid in, not pulled.

On reaching the analyzer house, sufficient bundle should be pulled off the reel to route into the analyzer house and to the analyzer cabinet. Contact Dekoron / Unitherm Customer Service for recommendations on bulkhead fittings and entry seals for this application.

METHODS OF BENDING

Bending the Dekoron / Unitherm traced products can be accomplished by various means, depending upon the product type and size. In any case, no bend should exceed the minimum bend radius. Exceeding the bend radius can result in damage to the bundle jacket, core tubes, and heater (see Figure 4). Since most analyzer bundles are constructed using fluoropolymer tubing, they can be bent by hand. If there are metal tubes or a number of messenger wires in the core, other methods may be needed. A thin wall conduit or MCM cable bender can be used with the smaller O.D. tube bundles. Other types of benders can also be used for all products if care is taken to prevent flattening of the tube(s) or damaging or misplacing the heating element. (A small amount of wrinkling in the jacket is normal and does not indicate bundle failure or loss of bundle properties.

A stationary mandrel may also be used for bending. The mandrel, such as a cable reel flange, should have a diameter of twice the minimum bend radius of the particular product. If the mandrel is smaller than twice the minimum bend radius, the complete bend cannot be made in one operation. Several large curvature bends must be made throughout the entire bend area so as not to exceed the minimum bend radius. The installer should also use this procedure when hand bending.

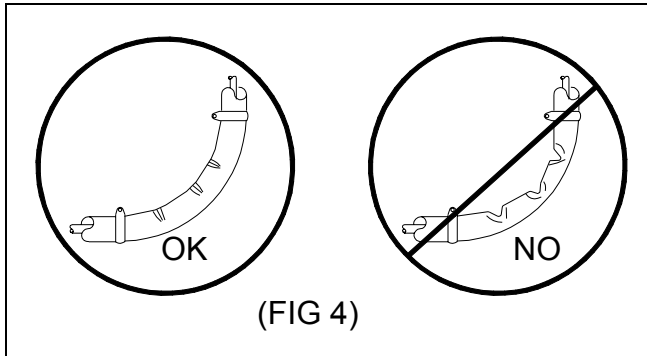

The installer should also use this procedure when hand bending.

PAYOFF METHODS

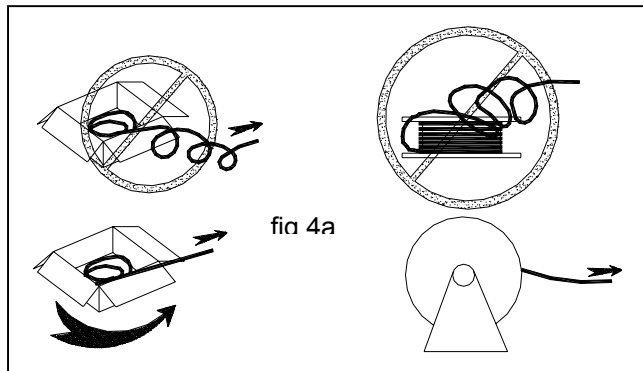

A free-wheeling payoff stand should always be used when uncoiling analyzer bundles. Back tension should only be enough to keep the reel from overrunning the pull. Tension should always be minimal. **Do not pull the bundle over the edge of the reel.** Care should be taken when removing heated hose products from cardboard containers. Either rotate the container or the hose when removing to prevent kinking.

HANGING AND SUPPORTS

Dekoron / Unitherm traced products should be supported securely according to the support center dimensions shown in the Dekoron / Unitherm catalog. In addition to these dimensions, the product should be securely supported within 18 to 24 inches of any connection kit. Suggested support methods are listed below.

1. ANGLE IRON

Angle Iron, sized to the closest 1/2" to the nominal bundle O.D., can be used effectively to support long vertical or horizontal single bundle runs. The Dekoron / Unitherm traced product is secured to the angle iron with either plastic or metal strap ties (Figure 6). As always, strap ties should have wide bearing area and should not be so tight that they deform the jacket of the analyzer bundle more than 1/8 inch. Horizontal runs should have the angle iron over the Dekoron / Unitherm traced product to prevent containment of water, ice and snow.

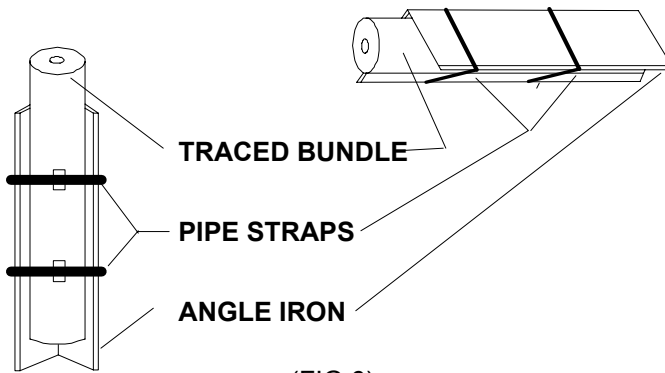

(FIG 6)

2. CHANNEL IRON

Channel Iron can be used in the same manner as angle iron, but can accept multiple bundles if sizing is made to allow bundle separation. Strap ties may also be used here.

3. CABLE TRAY

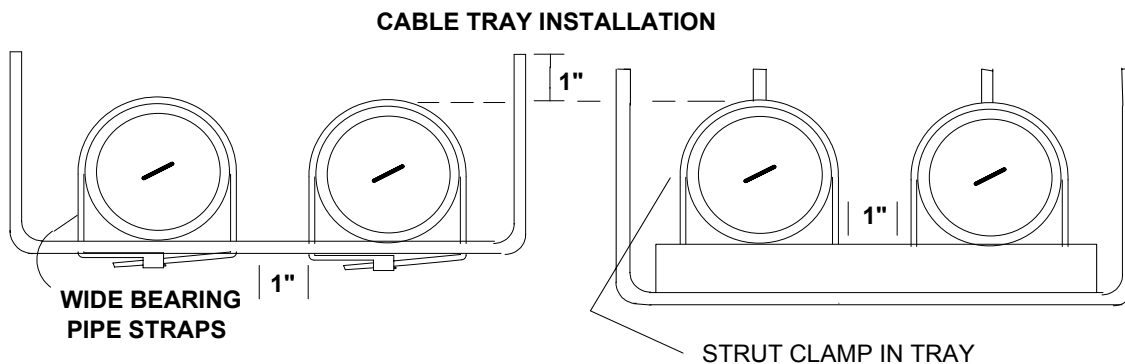

Figure 7

Standard industrial grade cable trays are best suited for multiple product runs. The product should be anchored to the tray to maintain clearance between the bundles. Securing each bundle to the tray within 6" to 10" of either side of a bend is recommended. The minimum spacing rule of 1 inch should apply on straight runs and bends (see Figure 7). Cable tray bends should be sized to the next standard size above the minimum bending radius of the bundle.

4. PIPE OR TUBE SUPPORTS

Dekoron / Unitherm recommends individual supporting hardware that has large supporting surface areas and cannot be over tightened to the point where the support can crush the product and damage the core tube or heating element (see Figure 8).

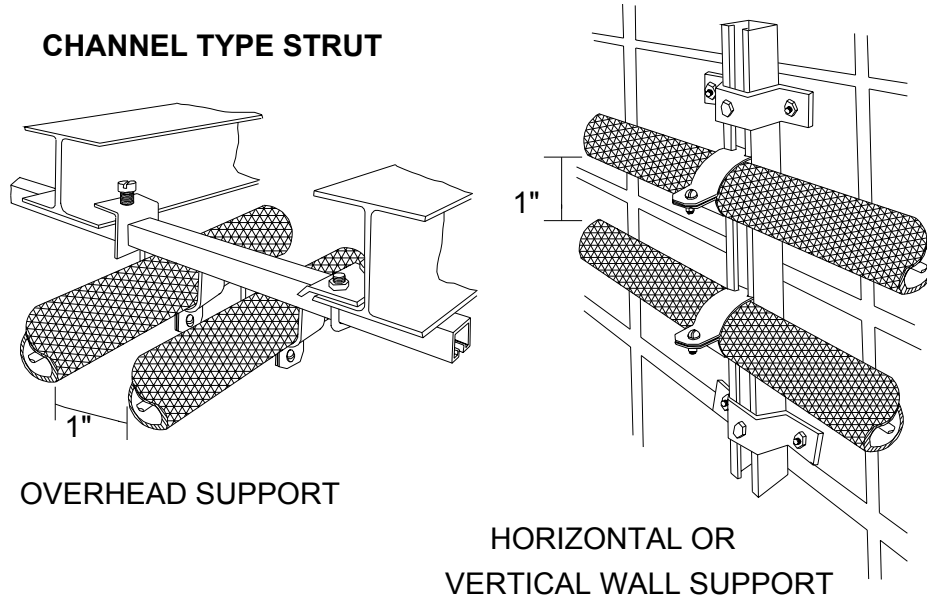

Figure 8.

Strut clamps are sized according to the bundle diameter and the location of the clamp. Clamps used on horizontal runs are sized to the nearest standard size greater than the bundle diameter. This allows the bundle to expand and contract through the clamp. Clamps used on vertical runs are sized to the nearest standard size less than the bundle diameter. This provides a secure anchor for the vertical run. Smooth radius bends at each end of the vertical run are recommended.

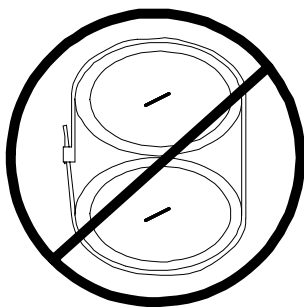

Figure 9.

Do not use wires or thin ties to tie bundles together or to attach bundles to hangers. These deform the jacket and insulation, reducing bundle efficiency and life.

SUGGESTED HANGER TYPES ARE: TYPES OF USE

| | |
|--------------------------------------|--------------------|
| Double Bolt Hangers | Support and Anchor |
| Band Hangers | Support |
| Split Steel Hanger | Support and Anchor |
| F & M Hanger | Support and Anchor |
| Short Clip Hanger | Support and Anchor |
| Sliding Guide Support | Support and Anchor |
| Refrigeration Clevis Hanger | Support |
| Auto Grip Insul-Speed Hanger | Support |
| Copper Tubing Adjustable Ring Hanger | Support |

THERMAL EXPANSION

The construction of the Dekoron / Unitherm traced products inherently allow for movement caused by thermal expansion and contraction. The minimum bend radius is large enough to absorb tube movement due to expansion. If there are no bends in a run using a single metal process tube product, some method, such as an expansion loop, should be used to take up the movement.

ELECTRICAL CONNECTIONS

The following section deals with terminating and connecting Dekoron / Unitherm heated analyzer bundles to electrical power. *If the bundle is factory sealed and terminated (common with Dekoron / Unitherm Heated Hose products), follow the instructions on the label attached to the power lead wires. The power lead wires are the two white (or one white and one black) and one green wire exiting from the power sleeve at the power end of the bundle.*

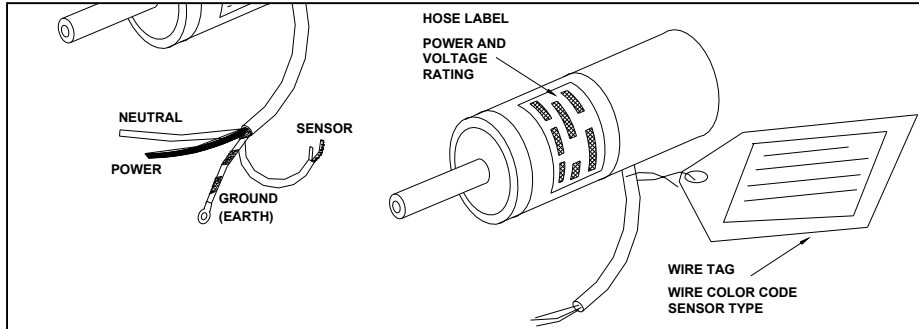
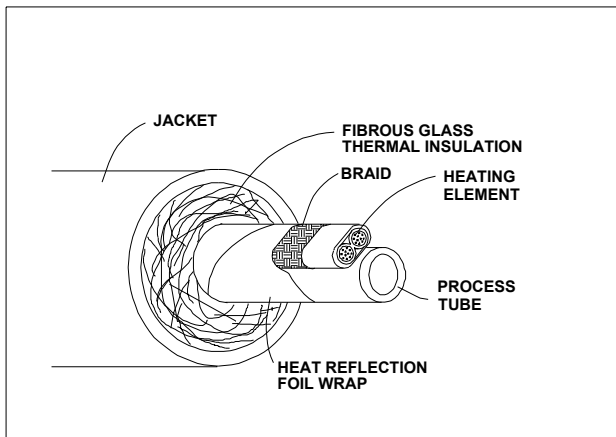

Figure 9a – Hose Tags



The 2252, 2256, 2262, and 2266 products use a parallel resistance heating element with bus wires. These wires can be connected directly to the power supply wires after separation. These bus wires **must not** be connected together on the termination end and must be electrically isolated from one another.

Figure 10 –
TYPICAL ELECTRIC TRACED BUNDLE

CONNECTION KITS

Electrical connection kits are offered that provide an electrical enclosure and weather tight connection. Figure 11 shows a Dekoron / Unitherm P/N 1548-12000 Electrical Connection Kit for customers who wish to use their own electrical enclosure, and P/N 1548-1200J Electrical Connection Kit with enclosure. This kit contains all the components necessary to make: (1) input power connection; -or- (1) input power splice connection; -or- (1) splice connection; -and- (2) termination connections.

Part Number 1548-1200J Kit content

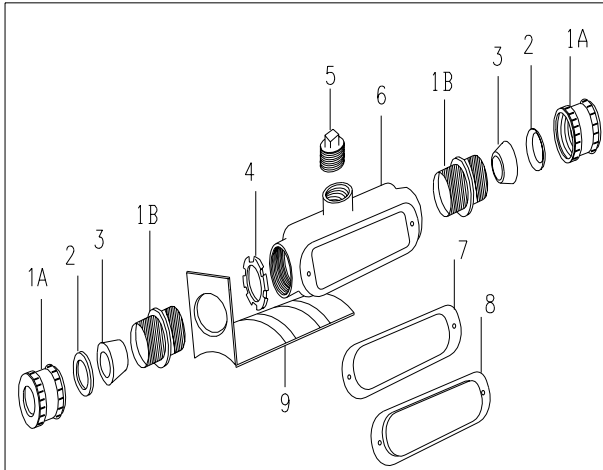

| ITEM NO. | DESCRIPTION | QUANTITY |
|----------|------------------------------|----------|
| 1 | CONNECTOR | 2 |
| 2 | METAL WASHER | 2 |
| 3 | GROMMETS | 4 |
| 4 | 3/4 LOCKNUT | 1 |
| 5 | 3/4 PIPE PLUG | 1 |
| 6 | CONNECTION BOX | 1 |
| 7 | CONNECTION BOX GASKET | 1 |
| 8 | CONNECTION BOX COVER | 1 |
| 9 | MOUNTING BRACKET | 1 |
| 10 | 5/16" SILICONE RUBBER SLEEVE | 3 FT |
| 11 | 7/16" SILICONE RUBBER SLEEVE | 3 FT |
| 12 | HARDWARE PACKAGE | 1 |
| | a) END BOOT | 2 |
| | b) CAUTION LABEL | 1 |
| | c) SILICONE TUBING | 1 |
| | d) SILICONE SEALANT | 1 |
| | e) HI-TEMP TAPE | 1 |
| | f) CABLE TIE | 2 |
| | g) 10-12 GA. BUTT CONNECTOR | 3 |
| | h) 14-16 GA. BUTT CONNECTOR | 2 |

* CONNECTION BOX, GASKET & COVER (6,7,&8) NOT INCLUDED IN 1548-12000 KIT

This information is provided with each 1548-1200J and 1548-12000 connection kit.

- Strip 8" of jacket and thermal insulation from product end, carefully exposing the process tube(s) and heating element.
- Place the metal bracket (9) on the bundle jacket, 1/2" from the end of the bared section and tighten cable ties.
- Attach the connection box (6) to bracket with one weather tight connector.
- Feed the heater through the connector cap (1a), metal washers (2), and the silicone grommet with the slotted hole (3). Insert the grommet into the connector body (1b) and tighten the cap.
- Thread power leads (not furnished) through the connection box opening and attach to heater leads using the insulated crimp connectors (12g or 12h) supplied in kit. See heater-stripping instructions following. Insulate connections with high temperature tape (12e).
- Attach the gasket (7) and cover (8). Insert the plug (5) into the open end of box. Attach the caution sticker (12b) to box.
- Push thermal insulation inside the end of the bundle jacket approximately 1/4" and fill void with RTV sealant (12d).
- All electrical components and connections **must** follow the National Electric Code and all Local Codes.

INSTALLATION INSTRUCTIONS

UNITHERM™

HEATER INSULATION STRIPPING INSTRUCTIONS

A. CPD HEATER

The Constant Power Density (CPD) heating element used in Dekoron / Unitherm 2252 and 2262 Series bundles is constructed of two parallel, stranded, nickel plated copper bus wires with spiral wound zones of high resistance heating wire. Alternating bus contact at fixed intervals form a chain of parallel zones equal resistance producing constant power output in each zone. These circuits, or zones, can be found by feeling for a small lump on the edge of the heater. (see Figure 12)

Since the heating zone must be connected to both bus wires to operate, the wire past the last bus connection to the end of the heater will be cold. Care must be taken or the first one to two feet of the bundle will have no heat.

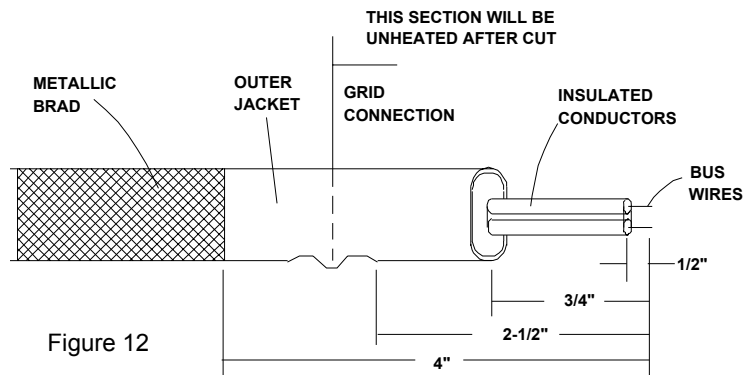

Figure 12

diameter heater wire, exposing both insulated conductors.

1. Cut heater 2-1/2 inches from the last grid connection.

2. Push back the tinned copper braid 4 inches from the end of the heating element. Secure temporarily with tape.

3. Slit the heater down the center 3/4 inches from the end. Score around the outer jacket 3/4 inches from the end.

4. Remove the outer jacket and small

5. Split the insulated conductors down the center.

6. Remove the conductor insulation 1/4" from both conductors.

CUTTING AND SEALING HEATED HOSE BUNDLES

Heated Hose products are shipped electrically and hydraulically complete. As such, no additional steps are required to place them into service.

Some Heated Hoses, 2H52, and 2H62 products can be field trimmed by qualified personnel. Contact Dekoron / Unitherm for details.

B. SR HEATER

Dekoron / Unitherm employs two different Self Regulating Heating Elements in its 2256 and 2266 Series bundles. A Low Temperature Self Regulating (SR) heater is used for freeze protection applications while a High Temperature SR heater is used for viscosity maintenance applications and where steam blow-down of lines is used.

Both heaters are continuous parallel heaters (no zones) and can be cut at any point without loss of heating capabilities.

INSTALLATION INSTRUCTIONS

UNITHERM™

Low Temp SR

1. Push back braid 4 inches from the end of the heater. Secure temporarily with tape.
2. Remove the outer jacket about 1 inch from the end of the heater, exposing the black, conductive polymer core.
3. Cut out the web of core material 1/8 inch wide and 3/4 inch long.
4. Strip the conductive core 3/8 inch from the end of each bus wire, using wire strippers.

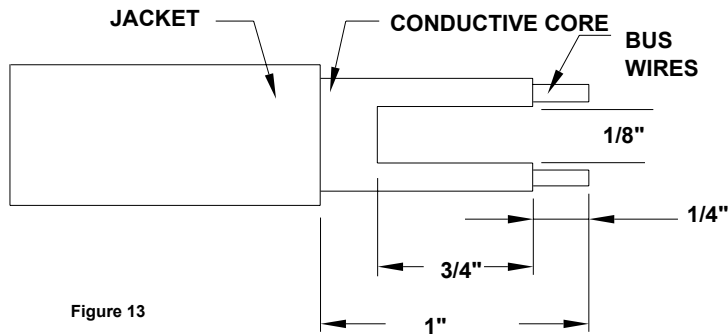

Figure 13

High Temp SR

1. Push back braid 4 inches from the end of the heater. Secure temporarily with tape.
2. Remove the outer jacket about 1 inch from the end of the heater, exposing the black, high temperature conductive core.

3. Cut out the web of core material 1/8 inch wide and 3/4 inch long.
4. Score around each bus wire 1/4 inch from the end, being careful not to cut the wires inside.
5. Bend the core material at the scored points of each bus wire with pliers to break the core-to-wire bond.
6. Remove the core material from the conductor with a razor blade or utility knife.

SPECIAL BRAID TERMINATION FOR CLASS I DIV 2 AREAS

This procedure must be followed to correctly terminate the metallic braid when installing the heater in Class I Division 2 Hazardous Areas.

1. Slightly flare out the heating element's metallic braid and slide it back about 3 inches.

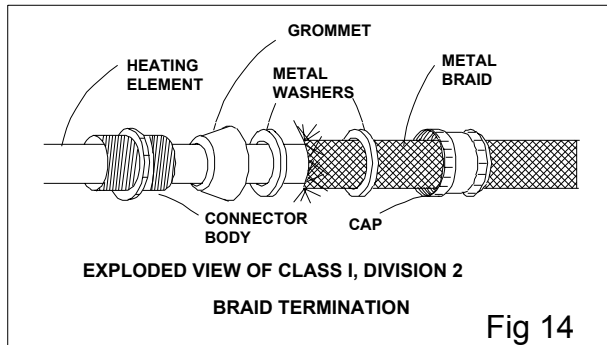
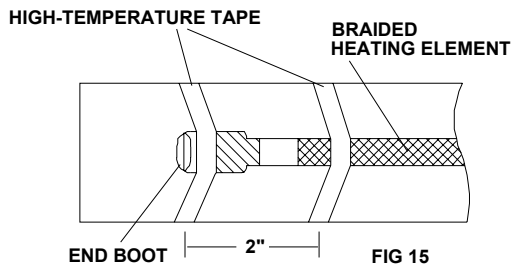

Fig 14

2. Feed the heating element through the cap, washers, and grommet of connector assembly.
3. Slide the metallic braid through the cap and then between the metal washers.
4. Push washers against the grommet, with braid captured between them, install cap and carefully tighten. (See Figure 14)

NON POWERED END TERMINATION PROCEDURE

Both the CPD and SR heaters are terminated in a similar manner. Care must be taken that the bus wires are not tied together at this end. Care must also be taken that the metallic braid does not come into contact with the bus wires, the fine gauge heating wire on the CPD heater, or the black conductive core on the SR heaters. (See Figure 15)



1. Push back metallic braid 3 inches from the end of the heater and temporarily secure with tape.
2. Trim the end of the heater so that one bus wire is 1/4 inch shorter than the other, making sure that the conductors are not shorted together.
3. Apply RTV sealant liberally to the end of the heater and into the end of the silicone end boot provided in the kit.
4. Slide the end boot over the end of the heater and

5. clamp in place (clamp provided in kit), secure with high temperature fiberglass/silicone tape.
6. Slide the copper braid over the end cap, twist the ends of the braid together to form a short pigtail.
7. Anchor the heater to the bundle core with high temperature tape.

SEALING TERMINATION END OF BUNDLE

The termination end of the bundle can be sealed from moisture using the RTV sealant supplied in the kit.

1. Push thermal insulation inside the bundle end about 1/4 inch.
2. Fill void with RTV sealant.

If the end of the bundle is in a "wash-down" area or any place where additional protection is necessary, a

double seal can be provided using a Dekoron / Unitherm 1540-10000 Seal Patch kit. (See Figure 16)

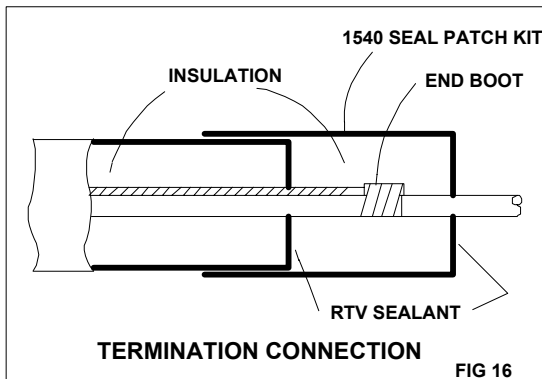

1. Seal the end of the bundle as outlined above.
2. Wrap thermal insulation supplied in Seal Patch kit around core, building to the diameter of the bundle.
3. Form Seal Patch over insulation and bundle jacket and seal together.
4. Press back thermal insulation and seal with RTV as outlined above.

INSTALLATION WITHOUT CONNECTION KITS

Use of the Dekoron / Unitherm 1548-12000 or 1548-1200J connection kit is a convenient way to insure a safe power connection and termination in all applications, and is required if the installer is terminating in an area classified as hazardous under the National Electric Code. If the installation does not require the use of these connection kits, certain procedures must be followed:

1. The heating wires must be connected to the cold lead wire or spliced together with an approved crimp connector which will withstand the temperatures generated.
2. The connections should be insulated with high temperature electrical insulating tape.
3. The ends of the product should be sealed to prevent the entry of water. Sealing can be done by using a sealing grommet type bulkhead connector for entrance into an instrument enclosure, analyzer cabinet or a power supply cabinet. A high temperature sealant or cement, such as Part No. 1535-02080 End Sealant can be used to encapsulate the end. Whichever method is used, the National Electrical Code and all local codes must be followed.

Allow a minimum braid length of 6" for input power and termination kits and 12" for input power splice and splice kits.

Detailed and comprehensive installation instructions for all accessory items are provided with the kits.

Thermostat (1660-13A12 & 1660-18912)

The thermostat can be used in conjunction with a connection kit or in line with the power supply. If the thermostat is to be kit mounted, the kit must be placed so the thermostat will sense the true ambient or tube temperature and not the temperature generated by a boiler, reactor, heat exchanger, or other heat source.

FINAL CHECKS

1. Check that all hangers and supports are secure to bundle, but not overly tight.
2. Check for extreme jacket kinking and for bends less than the minimum radius.
3. Check that all electrical connections are tight and properly insulated.
4. Check that heating element is not in contact with the temperature sensor.
5. Check that all connection kit covers have gaskets and are fastened tightly.
6. Check that all connections and components meet NEC and all Local Codes.

In addition to the above tests, the installer may elect to run a series of pre-commissioning tests. These tests check the electrical and pneumatic integrity of the analyzer bundle. Dekoron / Unitherm has developed a series of pressure / vacuum / electrical tests for this purpose.

Pre-Commissioning Test Program for Dekoron / Unitherm Analyzer Bundles

1. Scope

This procedure covers pressure and vacuum tests performance on sample line tubing and electrical tests performance on electric heating elements prior to commissioning Dekoron / Unitherm electrically heated analyzer bundles.

2. Equipment Required

- a. pressure gauge capable of reading 0-30 psig
- b. vacuum pump with gauge and flowmeter (typical analyzer sample pump)
- c. portable volt-ohm meter
- d. portable megger

3. Procedure

3.1 Pressure Test

The purpose of the pressure test is to determine if there are any leaks or pinholes in the sample tubing.

1. Cap the tubing at the probe end of the bundle.
2. Pressurize the sample tube to 30psig and close off the supply.
3. Watch the pressure gauge for any drop.
Typically, the tube pressure could drop up to 5 psig over 10 minutes due to cooling of the air, any further drop could indicate a leak.
4. If the gauge pressure drops more than 5 psig in 10 minutes, check all connections to insure that there are no leaks at the connection points, and repressurize the tube.
5. If the gauge pressure again drops, and there are no detectable leaks at the fittings, check for mechanical damage at the ends of the bundle, where the tubing is unprotected.
6. Continued pressure drop with no observable leaks indicates a pinhole within the bundle.

3.2 Vacuum Test

The purpose of the vacuum test is to determine if the tubing is plugged or kinked within the bundle.

1. Attach the probe end of the bundle to a filter to prevent dust and dirt from being drawn into the sample tube.
2. Attach the analyzer end to the analyzer pump or auxiliary vacuum pump.
3. Energize the pump and record the air flow rate and vacuum level.
4. The values recorded above must be within the analyzer manufacturer's specification to insure that the proper sample volume is pulled into the analyzer.
5. A high vacuum level with very little flow could indicate a kink or plug in the sample line.

6. A moderate to high vacuum level with normal flow could indicate the sample line is undersized for the flow rate required and the length of the sample line.

- 7. A moderate to low vacuum level with normal flow indicates there are no plugs or kinks in the sample tubing.

3.3 Electrical Tests

The purpose of the electrical tests are to insure that the heater is continuous and has no faults in its electrical insulation.

1. Tie the two heater bus wires together at the analyzer end of the bundle.
2. Read the resistance across these bus wires from the probe end of the bundle. Typical bus wire resistance should be less than 10 ohms.
A high bus wire resistance indicates a broken lead wire within the bundle.
3. Tie the two heater bus wires together at the probe end of the bundle and electrically insulate them to insure they do not short out against the braid or any ground point adjacent to the heater cable.
Note, the bus wires are tied together only for this test. They must be separated for final installation and termination.
4. Attach a portable megger at the analyzer end of the bundle
The positive lead of the megger should be connected to the two heater bus wires that were twisted together in the earlier test. The negative lead of the megger should be connected to the heater braid.
5. Megger the heater at 500 VDC.
The megger reading should be greater than 10Meg Ohm.
6. If the megger reading is less than 10Meg Ohm, check for contact between the braid and the heater bus wires at both ends of the bundle.

4. Testing Complete

On completion of the above tests, the sample line is ready for final installation and commissioning. Install termination and input power kits to bundle per the instructions supplied with the kits.

SUMMARY

The following list summarizes some of the important items to remember when installing **UNITHERM™** bundles.

INSTALLATION

| Don'ts | | Dos | |
|---------------|--|------------|--|
| DO NOT | EXCEED MINIMUM BEND RADIUS. | DO | PROVIDE LONG, SWEEPING BENDS WHERE POSSIBLE. |
| DO NOT | EXCEED RECOMMENDED SUPPORT CENTERS. | DO | SEAL ALL EXPOSED INSULATION WITH RTV END SEALANT. |
| DO NOT | OVERTIGHTEN SUPPORT CLAMPS-JACKET SHOULD NOT BE PINCHED. | DO | SEAL FITTINGS AND SPLICES WITH A SEAL PATCH |
| DO NOT | TIE MULTIPLE RUNS TOGETHER TO FORM ONE BUNDLE-PROPER SPACING(1/2" MINIMUM) IS REQUIRED FOR HEAT DISSIPATION. | DO | STRIP JACKET TO MAKE TIGHT 90 BENDS-USE A UNION ELBOW WHERE TIGHT BENDS ARE NECESSARY AND SEAL INSULATION. |
| DO NOT | SEVERELY CRIMP JACKET AS THIS MAY AFFECT INSULATION PROPERTIES, SOME SLIGHT CRIMPING CAN BE EXPECTED WITH HAND-FORMED BENDS. | DO | USE A MANDREL TO ASSURE CONSTANT RADIUS BENDS WHERE POSSIBLE. |
| DO NOT | REMOVE EXCESSIVE AMOUNTS OF JACKET AND INSULATION AT FITTINGS. | DO | SLOPE FOR CONDENSATE 3/4 IN. PER FOOT. |
| DO NOT | ALLOW THE HEATING ELEMENT TO BE IN CONTACT WITH THE SENSOR | DO | CHECK THAT ALL ELECTRICAL CONNECTIONS ARE TIGHT AND SEALED. |
| DO NOT | ROUTE ELECTRIC TRACE BUNDLES WHERE THE AMBIENT WILL BE ABOVE 120 DEG. F | DO | CHECK THAT ALL CONNECTION BOX COVERS HAVE GASKETS AND ARE FASTENED TIGHTLY. |
| | | DO | SECURE END KITS WHEN USING TEFLON TUBE TRACE PRODUCTS TO REDUCE STRAIN ON THE FITTINGS. |

FIG 16